



Universal Remote Profibus

XM-210 DP



Introduction

Thank you for choosing our Universal Remote Profibus XM-210 DP. To ensure its proper and efficient usage, it's important to read this manual thoroughly to understand how to operate the XM-210 DP, before putting it into operation.

About this Manual

1. This manual should be delivered to the end user of the XM-210 DP;
2. The contents of this manual are subject to change without notice;
3. All rights reserved. No part of this manual may be reproduced in any form without the written permission from DLG;
4. The specifications contained herein are limited to standard models and do not cover special products made by order;
5. All precautions has been taken for preparation of this manual, in order to guarantee the quality of information.

CAUTION!

The instrument described in this technical user manual is a device suitable for application in a specialized technical area. DLG supplied products are submitted to a strict quality control process. However, industrial control electronic equipment can cause damage to machinery or processes controlled by them in the event of any failure or improper operations and may even endanger human lives. The user is responsible for setting and selecting values of the parameters of the instrument. The manufacturer warns of the risks of incidents with injuries to both people and goods, resulting from the incorrect use of the instrument.

Contents

PRESENTATION	6
TYPICAL APPLICATIONS	7
TECHNICAL SPECIFICATIONS.....	9
Input Characteristics.....	9
General Characteristics and Precision	10
HOW TO SPECIFY	10
DIMENSIONS	11
MECHANICAL INSTALLATION	12
ELECTRICAL INSTALLATION	13
Power Supply	14
Digital Inputs.....	14
Relay Outputs and Alarms.....	15
Coding bits for alarms.....	16
Thermocouple inputs	17
Current inputs	18
Voltage inputs.....	18
Logic level inputs	19
OPERATING.....	22
Starting the XM-210 DP.....	22
Indication	25
Test button.....	25
RECOMMENDATIONS.....	26
WARRANTY	27

Presentation

The Universal Remote Profibus XM-210 DP is designed to promote versatility and robustness in industrial plants.

With its processing core based in the ARM® technology, the XM-210 DP offers speed and accessibility to field variables through the Profibus DP protocol over the RS-485 physical interface, thus enabling the acquisition of 16 inputs from several kind of signals such as thermocouples, RTD resistive sensors, current, tension, frequency and logical levels.



Picture 1

The available inputs and product features are described below:

- Thermocouples type J, K, T, R, S, E, N, B (ITS-90) with cold junction compensation
- RTD type PT-100 (two or three wires)
- Current 0-20 mA e 4-20 mA
- Tension 0-75 mV, 0-5 V e 0-10 V
- Logical level maximum amplitude 10 Vdc
- Frequency up to 10KHz with 4 simultaneous channels with 0,3 V to 50 V sensibility
- 2 digital inputs isolated up 30 V for of alarms and status recognition
- 2 alarm levels per channel, configurable (high, low, differential) with hysteresis and delay of 1 to 10 seconds
- 2 relay outputs for alarm status
- Fully detachable (plug-in type) connection to the terminal block

Typical Applications

The Universal Remote Profibus XM-210 DP is designed to several types of industrial applications, easing the concentration of distributed field data. The XM-210 DP applications demonstrate high optimization in remote field data acquisition, which were previously delegated to controllers, increasing the process scalability and decreasing costs.

All the 16 inputs of the XM-210 DP acquire field data reliably for the supervision and control systems, so the universal remotes can be highly used to collect information from any point of the plant floor.

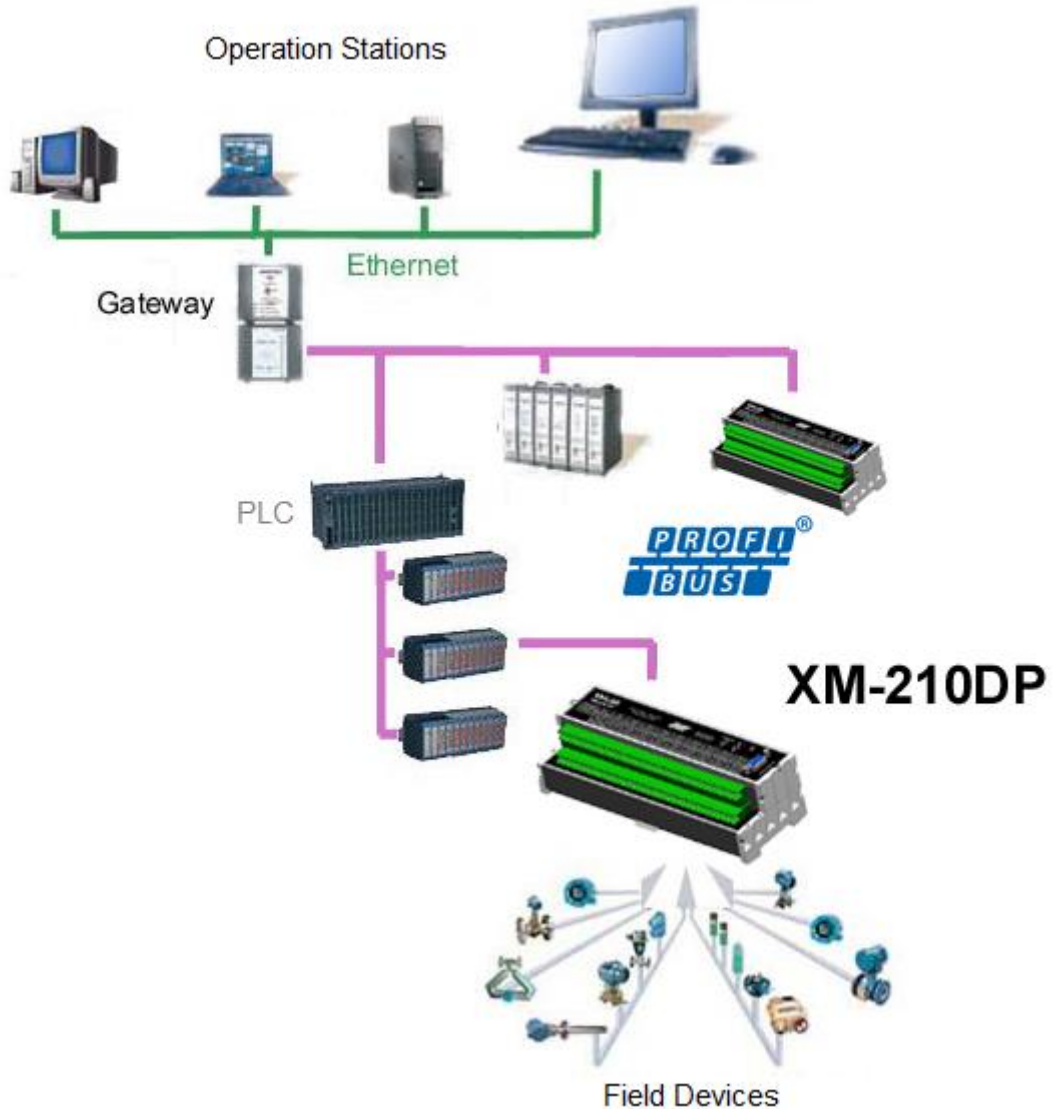

Picture 2 – Profibus network topology with the XM-210 DP

Technical Specifications

Input Characteristics

Type	Parameter	Min.	Max.	Comments	Unit	
Input Signal	Current	0	20	lin < 22mA	mA	
	Voltage	0	10	Vin < 10,5V		Fin < 2Hz
	Logic Level	0	10			
	Thermocouple		-270	1820	B, J, K, N, R, S, T	°C
			-180	1000	E	
	Cold Junction Comp.	-10	+60	Operation range		
	PT-100	-200	850	Two or Three wires		
Frequency	0.0004	10	0.3 to 50 Vdc sensibility	kHz		
Input Impedance	Current	49			Ω	
	Voltage	5			MΩ	
	Thermocouple	5				
	PT-100	5				
	Frequency	150	@10Vp 10KHz		KΩ	
A/D Precision (FS)	Current	0-20	± 1		uA	
		4-20	± 1			
	Voltage	0-75	± 0.003		mV	
		0-5	± 0.25			
		0-10	± 0.5			
	Thermocouple	± 0,1			%	
	PT-100	Pt	± 0.1			
Cold Junction Comp.	± 1.5			°C		
Linearization	Thermocouple	0.1			°C	
	PT-100	0.2				
Frequency Precision	0.02 @10000Hz			%		
Digital Inputs	Current	0.4	4		mA	
	Voltage	0	26		Vdc	
	Frequency	0.1	20		Hz	

General Characteristics and Precision

Type	Comments
Alarms	Two relay outputs: RL1 e RL2 SPDT max. 3 A / 220 Vac
Communication	2 RS-485 ports, isolated and with transient protection filter Baud rates (bps): 9.6k, 19.2k, 45.45k, 93.75k, 187.5k, 500k, 1.500M, 3M, 6M and 12M Profibus DPV0 protocol
Operating temperature	-10 °C to 60 °C
Thermal stability	±0.005% / °C span @ 25°C
Relative humidity	Up to 90%
IP protection	IP-50 (DIN EN 60529 VDE 0470)
Input voltage	AC Version: 85 ~ 260 Vac, 50 - 60Hz DC Version: 18 ~ 30 Vdc
Power consumption	10 VA
Construction	Aluminum and side panels in PA 6.6-FR (flame resistant polyamide)
Placement	DIN35 rail (DIN EN 60715 TH35)
Electrical connection	Cable up to 2.5mm ² with "plug-in" type removable connectors
Aprox. Weight	0.5 kg
Dimensions	59 x 208 x 75 mm. (height x width x depth)

How to Specify

XM- _ 10 DP ___ ___	
Enclosure	
2	Standalone universal converter (XM-210DP)
6	Universal converter installed inside IP-65 box (XM-610DP)
Input Voltage	
AC	85 ~ 260 Vac
DC	18 ~ 30 Vdc
Details	
M	Indicates metallic IP-65 box (XM-610DP)
E	Provides universal connector for each input channel

Dimensions

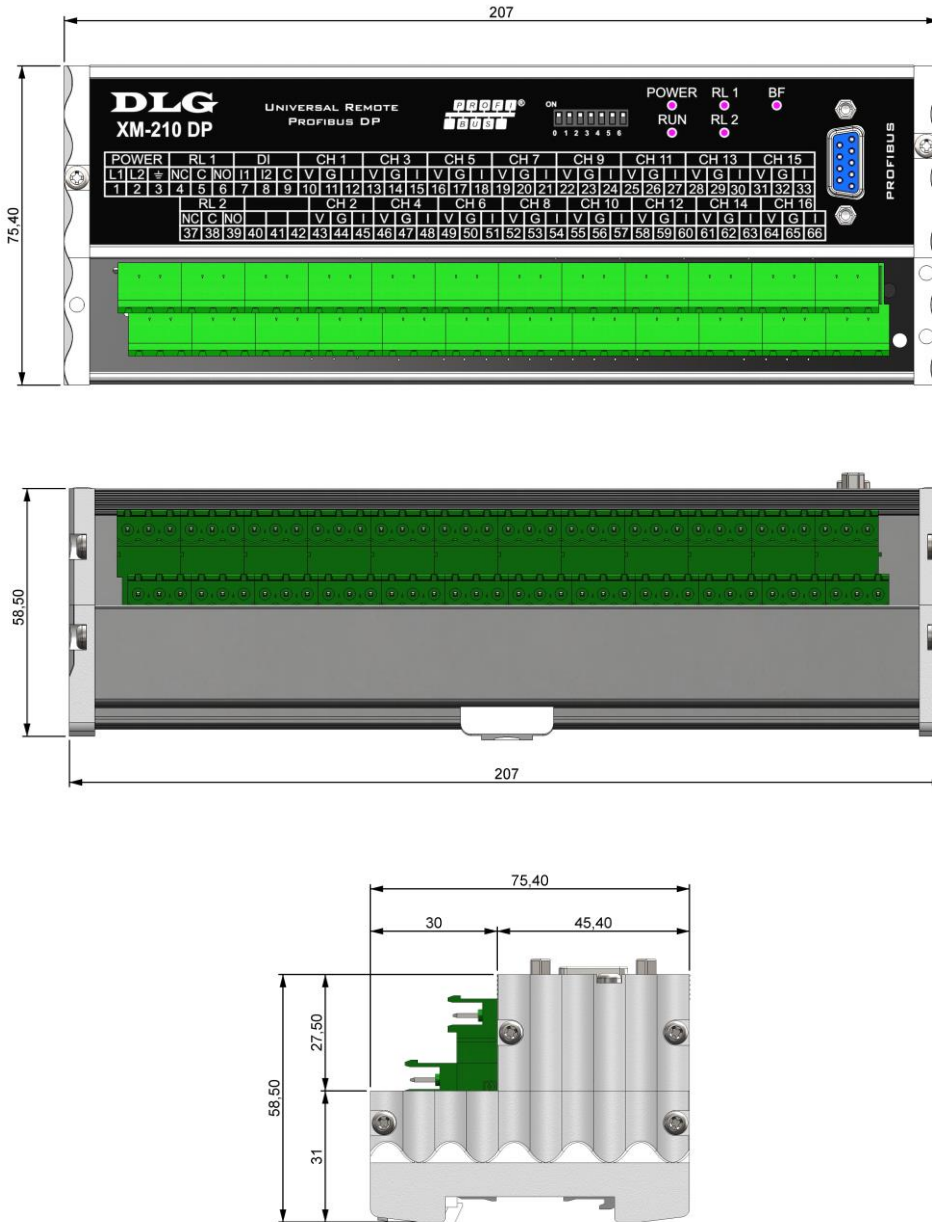

Picture 3 – Dimensioning for assembling (dimensions in millimeters)

Mechanical Installation

To correctly install the Universal Remote Profibus XM-210 DP an appropriate screwdriver shall be used so the mechanical parts are not damaged. A “terminal” type 1/8” screwdriver is recommended. The following steps details the installation.

1. Place the bottom of the XM-210 DP in the DIN 35 mm rail as shown in Figure 4.



Figure 4

2. Press the top part of the XM-210 DP until hearing a click. To remove the XM-210 DP, just apply opposite force, i.e., force the XM-210 DP up and pull it out.



Figure 5

3. The XM-210 DP is designed to be installed in regular DIN 35 mm trails and after the installation the equipment must remain securely fastened and must not present any slack within the trail. If there is any slack, the trail is possibly not standard.

Electrical Installation

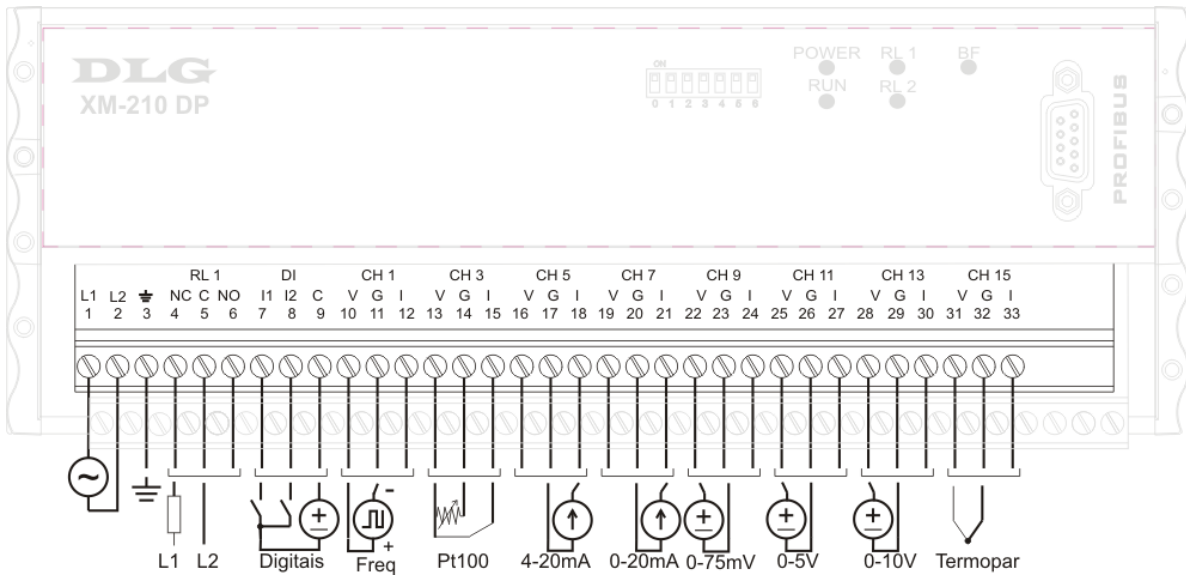

Picture 6 – Top Terminal

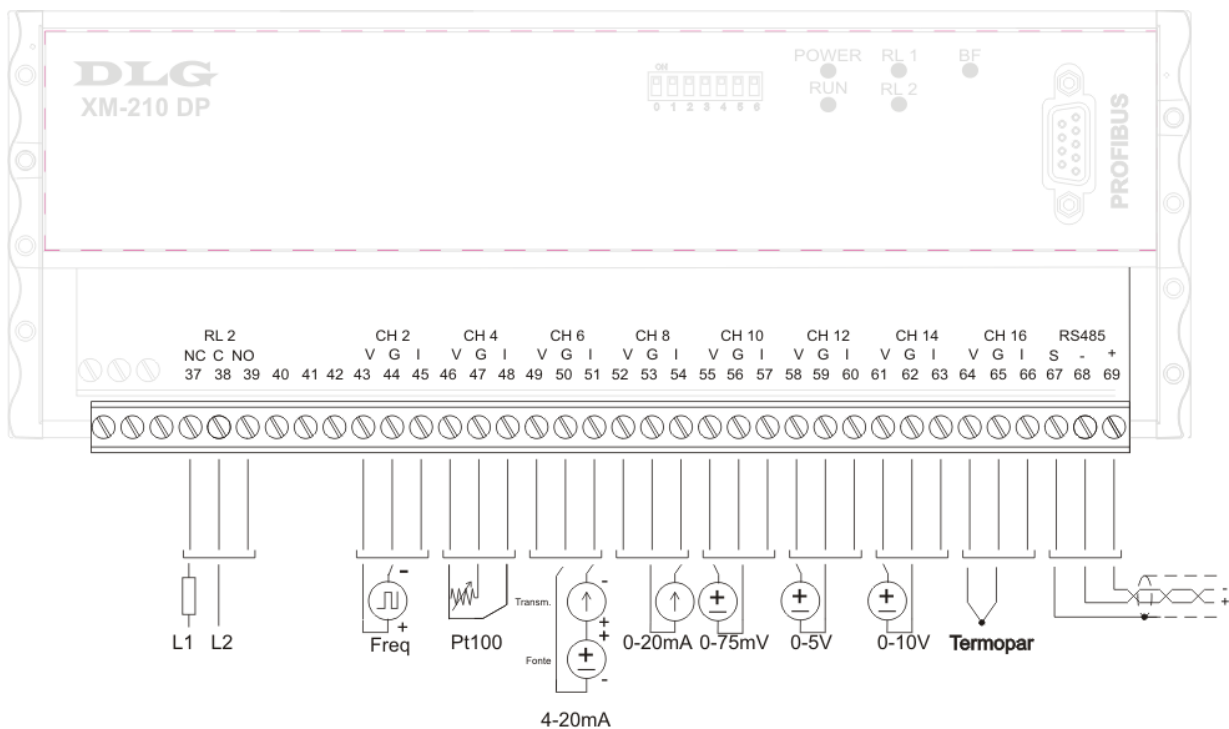

Picture 7 – Bottom Terminal

Attention: All cables must be “crimped” with eyelet type terminals for cables up to 1.5 mm unless otherwise stated. The XM-210 DP input type selection is done entirely through the GSD file and there are no configuration jumpers. It is recommended to use woven shielded cables and the woven grounding should be mostly done around the field instruments at just one point.

Power Supply

The XM-210 DP AC must be powered through terminals 1 and 2 with full-range voltage ranging from 90 to 260 Vac. The XM-210 DP DC must be powered through terminals 1 and 2 with voltage from 18 to 30 Vdc. Terminal 3 is used to ground the "mass" to the panel and it is recommended to use 1.5 mm² cables for the phases and 2.5 mm² for grounding. The electric scheme is described in the picture.

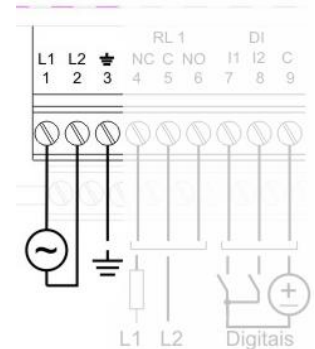

Note: There is no polarity on power terminals 1 and 2 for the XM-210 DP DC, i.e., the positive can be connected to terminal 1 and negative to terminal 2 or positive to terminal 2 and negative to terminal 1.

Digital Inputs

The digital inputs are used for alarm status and recognition. The inputs I1 and I2 are photo coupled, with sensibility from 10 to 30 Vdc, common for the two inputs, NPN driven. Digital input I1 is used to reset or recognize RL1 and RL2 alarm conditions and digital input I2 is used like a status flag for general use. The electric scheme is described in the picture where terminals 7 and 8 are the NPN inputs and terminal 9 the positive source common.

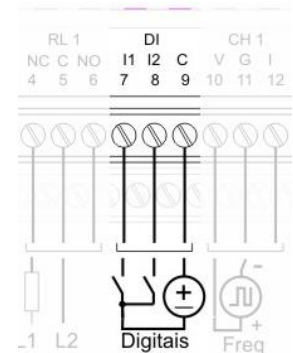

The digital inputs can be read through *slot 17 – Digital Inputs*.

Bit 0 – Input 1

Bit 1 – Input 2

Slot 15 – Digital Inputs	
Bit	Function
0	Digital input 1
1	Digital input 2
2	Error reading calibration memory (0: ok, 1 = error)

Relay Outputs and Alarms

The relay digital outputs can be used for general purpose, and can be configured through the output byte in slot 20 (Relay 1 and 2). The outputs can only be reseted through the slot in the table below this topic.

The electric scheme is described in the picture for the SPDT relay type, with the common contact connected to terminals 5 and 38, the NO contacts to terminals 6 and 39 and the NC contacts to terminals 4 and 37.

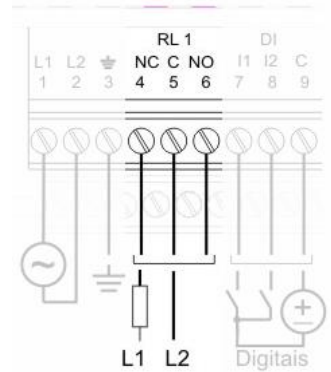

Slot 20 – Relay 1 and 2		
Value	Index	Action
1	xxxx xxx1	Deactivate relay 1
2	xxxx xx1x	Deactivate relay 2
3	xxxx x1xx	Activate relay 1
4	xxxx 1xxx	Activate relay 2

Bit 0 – Reset output 1 Bit 1 – Reset output 2
 Bit 2 – Set output 1 Bit 3 – Set output 2

The XM-210 DP has two independent alarms for each input channel totalizing 32 alarms.

Each alarm can be configured with up to 4 types of conditions: inoperative, low value, high value and differential.

Inoperative: No alarm.

Low value: The alarm is active as soon as the input value is lower than the set point.

High value: The alarm is active as soon as the input value is higher than the set point.

Differential: The differential mode is defined by the set point and the hysteresis. The set point defines the center reference point and the hysteresis increases the reference range. If the input signal lies inside the reference range that alarm is not active. Otherwise, if the input signal lies outside the reference range, the alarm becomes active. For example, to define a reference ranging from 400 to 600, define the set point as 500 and the hysteresis as 100. When the input signal is lower than 400 or higher than 600 the alarm is active.

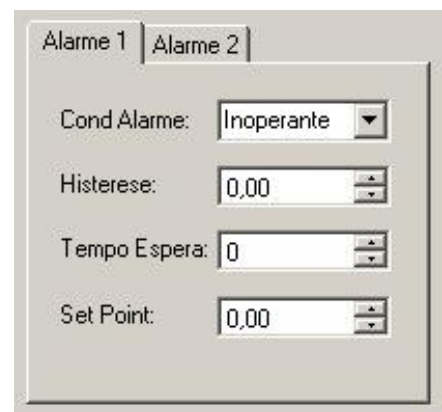

Figure 8

The hysteresis is the term relative to the delay between the activation or deactivation of a condition. In the XM-210 DP the operation mode can change according to the selected alarm condition.

For example:

With low value selected, the activation only happens after the input value is lower than the set point and deactivated when the input value is higher than the set point plus the hysteresis.

With high value selected, the activation only happens after the input value is higher than the set point and deactivated when the input value is lower than the set point less the hysteresis.

The waiting time defines how many seconds the output waits to be activated.

The set-point defines the alarm trigger.

Observations:

For greater security using relays in burn-out conditions, or when there is disruption of the PT-100 cable (see PT-100 input) it is recommended to configure the relay triggering wait time to more than 5 seconds. This condition is important to avoid operational failures, for example, turbine “trips” or any other system that relies on free error states, recalling that burn-out is an error condition of the process.

Coding bits for alarms

The table below indicates each bit between channels and alarms (4 bytes).

Slot 18 – Alarm 1		
Dec	Byte 0	Action
1	xxxx xxx1	Alarm 1 channel 1
2	xxxx xx1x	Alarm 1 channel 2
3	xxxx x1xx	Alarm 1 channel 3
4	xxxx 1xxx	Alarm 1 channel 4
5	xxx1 xxxx	Alarm 1 channel 5
6	xx1x xxxx	Alarm 1 channel 6
7	x1xx xxxx	Alarm 1 channel 7
8	1xxx xxxx	Alarm 1 channel 8

Slot 18 – Alarm 1		
Dec	Byte 1	Action
1	xxxx xxx1	Alarm 1 channel 9
2	xxxx xx1x	Alarm 1 channel 10
3	xxxx x1xx	Alarm 1 channel 11
4	xxxx 1xxx	Alarm 1 channel 12
5	xxx1 xxxx	Alarm 1 channel 13
6	xx1x xxxx	Alarm 1 channel 14
7	x1xx xxxx	Alarm 1 channel 15
8	1xxx xxxx	Alarm 1 channel 16

Slot 18 – Alarm 2		
Dec	Byte 2	Action
1	xxxx xxx1	Alarm 2 channel 1
2	xxxx xx1x	Alarm 2 channel 2
3	xxxx x1xx	Alarm 2 channel 3
4	xxxx 1xxx	Alarm 2 channel 4
5	xxx1 xxxx	Alarm 2 channel 5
6	xx1x xxxx	Alarm 2 channel 6
7	x1xx xxxx	Alarm 2 channel 7
8	1xxx xxxx	Alarm 2 channel 8

Slot 18 – Alarm 2		
Dec	Byte 3	Action
1	xxxx xxx1	Alarm 2 channel 9
2	xxxx xx1x	Alarm 2 channel 10
3	xxxx x1xx	Alarm 2 channel 11
4	xxxx 1xxx	Alarm 2 channel 12
5	xxx1 xxxx	Alarm 2 channel 13
6	xx1x xxxx	Alarm 2 channel 14
7	x1xx xxxx	Alarm 2 channel 15
8	1xxx xxxx	Alarm 2 channel 16

Obs: Para utilizar valores negativos em configurações como set point ou histerese, use: **65536 – valor_negativo**. Por exemplo, para set point a -100 °C, use: **65536 – 100 = 65436**.

PT-100 Input

The PT-100 inputs type are linearized according to ITS-90. With a current source circuit and cable compensation the XM-210 DP eliminates the line charging effect, and with resistive sensors measurement it stands as a precise temperature measurement system. The sensor measurement terminals are signal (G) and common (V and I) from channels CH1 up to CH16 and the cable compensation measurement is done in the I terminals referenced to **G**.

If the PT-100 cables are not connected or are open, a burn-out signal will be represented by an indication of -200°C in the respective channel.

The XM-210 DP detects the missing sensor and disables the alarm states associated to the open channel.

The PT-100 inputs can be read through slots 1 to 16 if they are configured as PT-100 through the channel sensor type parameter.

The scale of the signal is given by: $T \cdot 10$, ie to 100°C the value of channel is 1000.

Note: User should pay attention to the correct connection of the sensor (signal \rightarrow G and common \rightarrow V and I), otherwise indication of the temperature will fail. Incorrect connection may interfere on the other channels.

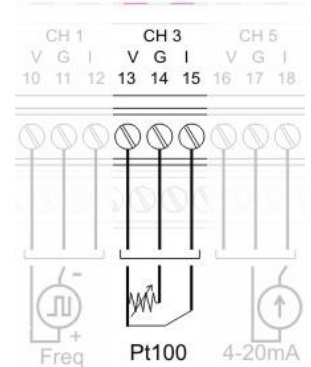

Thermocouple inputs

The thermocouple inputs are linearized as according to ITS-90. With a cold junction compensation circuit, the XM-210 DP eliminates the Seebeck effect in the cable connections, standing as a precise system for high temperature or high differentials measurements. The sensor measurement terminals are positive (V) and negative (G) from channels CH1 up to CH16. Terminal (I) is not used in this configuration. Terminal line (I) is not used in this configurations.

The thermocouple inputs can be read through slots 1 to 16 if they are configured as thermocouple through the channel sensor type parameter with the available thermocouple types.

The scale of the signal is given by: $T \cdot 10$, ie to 100°C the value of channel is 1000.

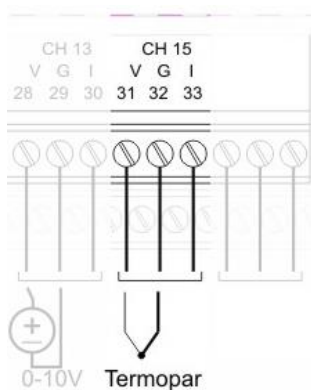

Note: The universal remote doesn't have burnout detection for voltage input, which means that, to avoid floating signal (**when sensor is disconnected**), the user should configure that channel as "Sem Entrada" (disabled) or to make a short-circuit between terminals V and G, to keep the input on 0 (zero).

Current inputs

The XM-210 DP has two current input configurations: 0-20 mA and 4-20 mA. The scheme for both configurations is described in the picture, where the current loop positive is connected to the line terminals (I) and the negative to terminals (G) from channels CH1 up to CH16. The positive terminals (V) are not used in this configuration.

The current inputs can be read through slots 1 to 16 if they are configured as current inputs through the channel sensor type parameter.

The scale of the signal is given by: mA*1000, ie to 20mA the value of channel is 20000.

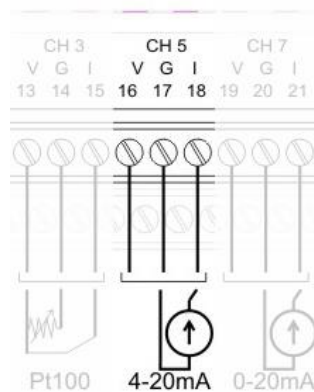

3 Wire Connection

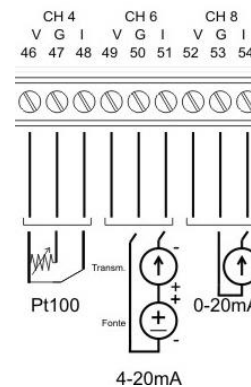

2 Wire Connection

Voltage inputs

The XM-210 DP has three voltage input configurations: 0-75 mV, 0-5 V and 0-10 V. The scheme for the configurations is described in the picture, where the positive is connected to the terminals (V) and the negative to terminals (G) from channels CH1 up to CH16. The line terminals (I) are not used in this configuration.

The current inputs can be read through slots 1 to 16 if they are configured as voltage inputs through the channel sensor type parameter.

The scale of the signal is given by: V*1000, ie to 10V the value of channel is 10000.

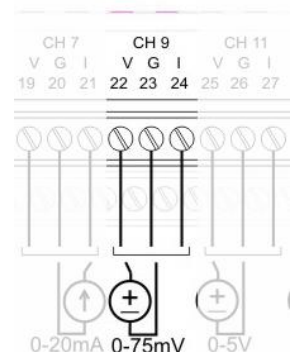

Note: The maximum allowed voltage for correct operation of the XM-210 DP is 10.5 V.

Logic level inputs

The XM-210 DP has logic level inputs with 0 to 10 Vdc sensibility. The 0 to 3 V range corresponds to logic level 0 while the 5 to 10 V range corresponds to logic level 1. The scheme is described in the picture, where the positive is connected to the terminals (V) and the negative to terminals (G) from channels CH1 up to CH16. The line terminals (I) are not used in this configuration.

The logic level inputs can be read through slots 1 to 16 if they are configured as logic level inputs through the channel sensor type parameter.

The scale of the signal is given by: $LL * 1$, ie to "1" the value of channel is "1".

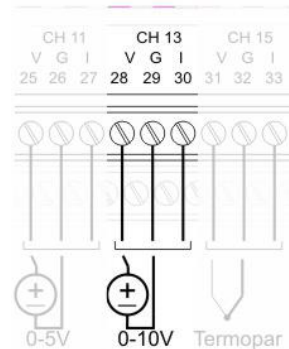

Note: The maximum allowed voltage for correct operation of the XM-210 DP is 10.5 V.

Frequency inputs

The XM-210 DP has frequency inputs with 0.3 to 50 Vdc sensibility and 0.3 Hz to 10 KHz reading. The scheme is described in the picture, where the positive is connected to the terminals (V) and the negative to terminals (G) from channels CH1 up to CH4. The line terminals (I) are not used in this configuration.

The frequency inputs can be read through slots 1 to 16 if they are configured as frequency inputs through the channel sensor type parameter.

The scale of the signal is given by: Hz*1, ie to 10Hz the value of channel is 10.

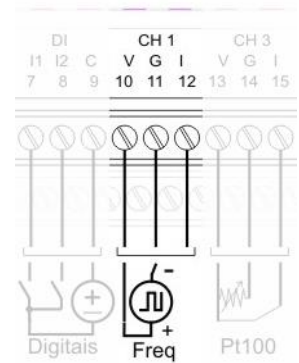

Profibus DP Communication

The XM-210 DP has one serial communications channels using the Profibus DP protocol over the RS-485 media. The indication is done by the BF (Bus Fail, red) led.

The picture describes the connection scheme of the communication channel. The positive is connected to terminal 69 and the negative to terminal 68.

Terminal 67 must be used for the communications cable woven.

Note: in some devices the labels A (green) and B (red) can be used for Profibus communications. In this case it must be connected to the negative and positive terminals, respectively.

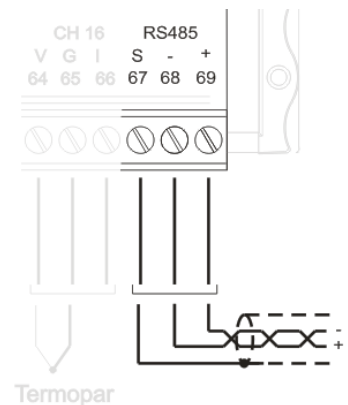

When using DB9 connectors commonly used with the Profibus DP protocol the frontal female DB9 connector of the XM-210 DP must be used.



The address assignment to the XM-210 DP in the Profibus network is done using the keys available at the frontal. The address is entered as a binary base number ranging from 1 to 125, for instance:

$$1 \cdot (2^0) + 0 \cdot (2^1) + 1 \cdot (2^2) + 0 \cdot (2^3) + 0 \cdot (2^4) + 0 \cdot (2^5) + 0 \cdot (2^6) = 5$$

NOTE: If the address is higher than 125 the XM-210 DP will indicate failure through the RUN led that will blink continuously with a 2 Hz frequency.

Operating

Starting the XM-210 DP

The Universal Remote Profibus XM-210 DP is designed to ally the advantages in the distribution and collection of the field variables with the Profibus protocol compatibility, being able to make them available along with its settings to controllers and supervision systems.

Through the GSD file and software as Simatic Manager © or Sycon©, it's possible to configure all the parameters in a structured way.

Some items from the XM-210 DP parameterization follow:

Configuration:

- Sensor type selection.
- Offset setting for each selected sensor.
- Alarm type selection: low, high or differential.
- Alarm hysteresis setting.
- Alarm set point setting.
- Waiting time for alarm activation.
- "Little endian" data (ex.: Channel1[0..1], Channel2[2..3] 0 and 2 least significant)

Output Alarms:

- Table for selecting outputs for the input channels.
- All input channels can be configured to activate the outputs.
- Each input channel can create a combination of outputs activation.
- Outputs 1 and 2 reset.

Led indications:

- Operation and communications indication through leds in the equipment.

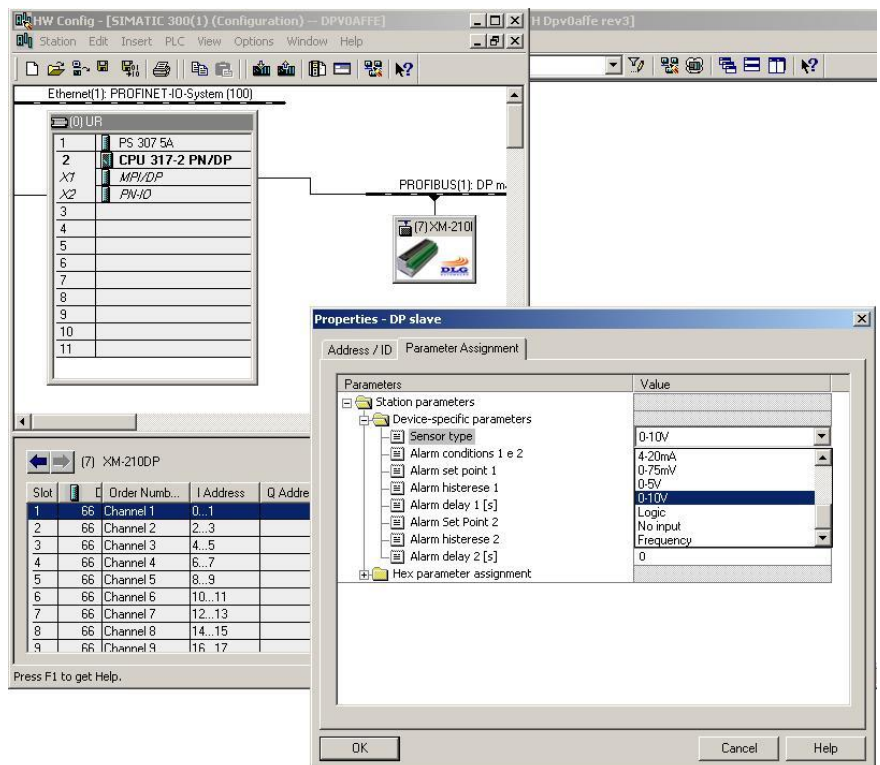

For some configurators, it is important to note that the modules available in the XM210-DP **must** be manually inserted and in the order they are displayed, for example: Channel 1, 2, 3 .. 16; digital inputs; room temp.; Alarms 1 and 2; Relay 1 and 2.

For proper operation, all modules must be inserted according to the window below:

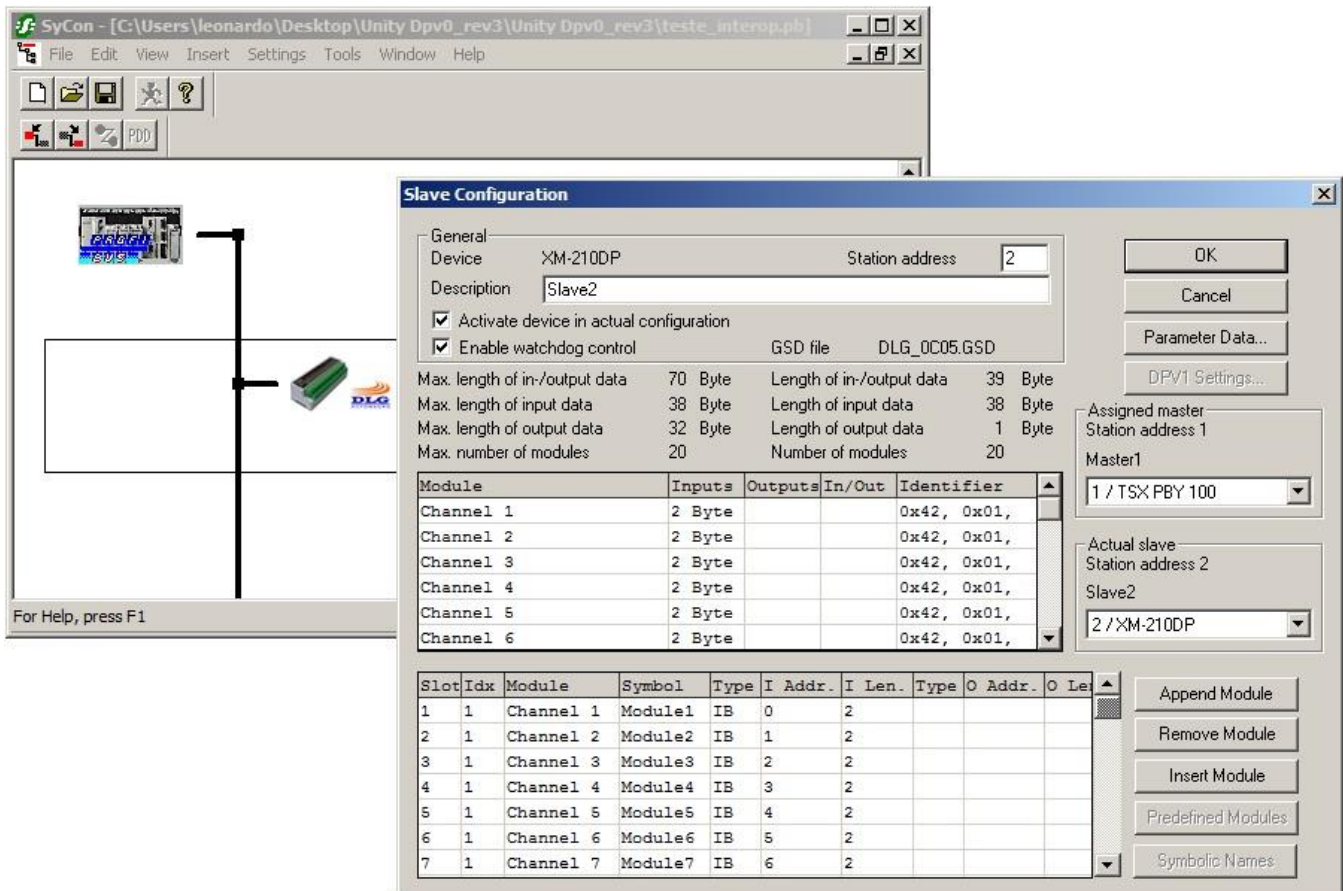

Slave Configuration

General

Device: XM-210DP Station address: 2

Description: Slave2

Activate device in actual configuration

Enable watchdog control GSD file: DLG_OC05.GSD

Max. length of in-/output data: 70 Byte Length of in-/output data: 39 Byte

Max. length of input data: 38 Byte Length of input data: 38 Byte

Max. length of output data: 32 Byte Length of output data: 1 Byte

Max. number of modules: 20 Number of modules: 20

Module	Inputs	Outputs	In/Out	Identifier
Channel 1	2 Byte			0x42, 0x01,
Channel 2	2 Byte			0x42, 0x01,
Channel 3	2 Byte			0x42, 0x01,
Channel 4	2 Byte			0x42, 0x01,
Channel 5	2 Byte			0x42, 0x01,
Channel 6	2 Byte			0x42, 0x01,

Slot	Idx	Module	Symbol	Type	I Addr.	I Len.	Type	O Addr.	O Len.
1	1	Channel 1	Module1	IB	0	2			
2	1	Channel 2	Module2	IB	1	2			
3	1	Channel 3	Module3	IB	2	2			
4	1	Channel 4	Module4	IB	3	2			
5	1	Channel 5	Module5	IB	4	2			
6	1	Channel 6	Module6	IB	5	2			
7	1	Channel 7	Module7	IB	6	2			

If the module sequence is not in the correct order, it will cause problems in the equipment.

When more than one slave in the bus is used, just select the slave and copy to the other addresses in the network, so all the modules and parameters of the slave also get copied. The address must be modified to be next address available in the PLC memory table.

For some configurators, the “endianess” option can be defined:

The screenshot displays the software interface for configuring the XM-210 DP. It includes several key components:

- Network Topology View:** Shows a hierarchical tree of modules including Profibus 1, REMOTA, and various input/output channels (e.g., Ambient temp, Alarms, Relay, and 7 Input Channels).
- Mapping Tool:** A window for defining memory maps with a grid for address ranges (0, 32, 64, 96).
- Scale Attributes:** A dialog box for setting scaling parameters for sensors and PVs (e.g., Sensor 100, Sensor 0, PV 100, PV 0, Units Index).
- Network Configurator - [PBusController 2.pb]:** The main configuration window showing:
 - Slave Configuration:**
 - General: Device XM-210DP, Station address, Description REMOTA.
 - Max. length of in-/output data: 70 Byte.
 - Max. length of input data: 38 Byte.
 - Max. length of output data: 32 Byte.
 - Max. number of modules: 20.
 - Module table with columns: SlotIdx, Module, Inputs, Outputs, In-/Out, Ident.
 - Table with columns: SlotIdx, Module, Symbol, Type, I Addr., I Len., Type 0.
 - Parameter Data:** A table listing parameters such as [SlotNumber], Sensor type (PT100), Alarm conditions, and Alarm set points.
 - Select Module:** A dialog for choosing a specific channel (Channel 1 to Channel 10).
- Network Diagram:** Shows a DP Master (DF73) connected to a DP Slave (REMOTA).

Indication

The XM-210 DP has state indication leds:

- Power: indicates that the XM-210 DP is energized.
- RUN: on startup it blinks 5 times per second and after 5 seconds stay turned on. If it keeps blinking after 5 seconds it is indicating failure.
- RL1 and RL2: The states of relays 1 and 2.
- BF: If Bus Fail is active it indicates that the XM-210 DP is not performing Data Exchange.

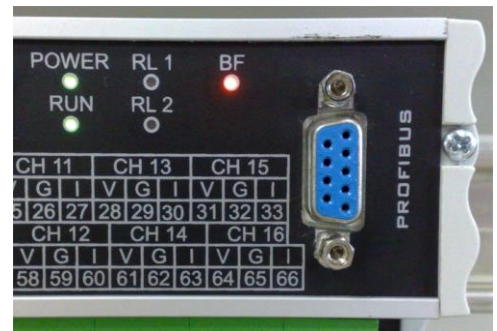

Test button



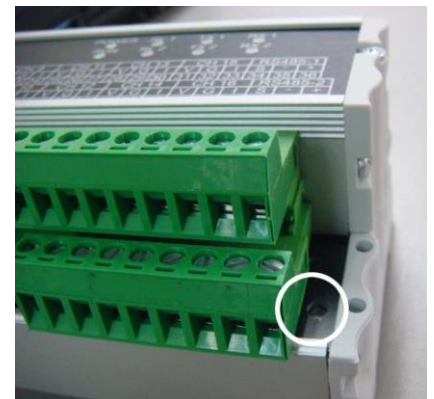

The test button located next to the terminals (see Picture) can be used for any purpose, making available a status bit that can be read through *Slot 17 Digital Inputs*.

Bit 3 – key



Recommendations

It's recommended to use only appropriate tools for the XM-210 DP installation and maintenance.

<p>It is necessary to use a “terminal” type screwdriver for terminal connection or 1/8 with 3mm maximum diameter, as it is the ideal format and will not damage the connection aperture.</p>	 <p style="text-align: center;">Inappropriate screwdriver</p>	 <p style="text-align: center;">Recommended screwdriver</p>
<p>It is recommended to crimp all the wires that will be connected to the XM-210 DP with a pre-isolated “needle” type or “eyelet” type terminal for cables of 0.5 - 1.5mm².</p>	<p style="text-align: center;">Needle Terminal</p> 	<p style="text-align: center;">Eyelet Terminal</p> 

Warranty

The manufacturer assures to the equipment owners, identified by the purchase invoice, warranty of 1 (one) year as follows:

- 1 - The warranty period begins on the data of the invoice issue;
- 2 - Within the warranty period, the labor and parts used for repairing damage occurred in normal use are free;
- 3 - For repairs, send the equipment along with the shipping invoices to our factory in Sertãozinho, São Paulo state, Brazil. DLG's address is available at the end of this manual;
- 4 - The owner is responsible for transportation costs and risks;
- 5 - Warranty will be automatically suspended if changed are made to the equipment by personnel not authorized by DLG, defects caused by mechanical shock, exposure to conditions unfit for use or tampering with the product;
- 6 - DLG disclaims any charge relating to unauthorized repairs or replacements due to failures caused by agents external to the equipment, the improper use of them and as a result of unforeseeable circumstances or major forces;
- 7 - DLG ensures full operation of the equipment described herein and all existing operations.

Notes



<p>DLG Automação Industrial Ltda. Rua José Batista Soares, 53 Distrito Industrial – 14176-119 Sertãozinho – São Paulo – Brasil Fone: +55 (16) 3513-7400 www.dlg.com.br</p>	<p>MAN-EN-DE-XM210DP- 01.00_16</p>	<p>UNIVERSAL REMOTE PROFIBUS XM-210 DP</p>
<p>DLG reserves the right to change this manual contents without notice in order to keep updating it with potential product developments.</p>		